

Paper Roll Lifters/Positioners

Model 23QS – QUICKSHIP Roll Lifting Beams



QUICKSHIP PROGRAM

PRODUCT FEATURES:

- Standard beam sizes.
- J-Hooks are custom cut per order to fit your specific application.
- Hooks can be fixed or pivot style.
- J-Hooks are quickly and infinitely adjustable between minimum and maximum spread.
- Complies with ASME standards.

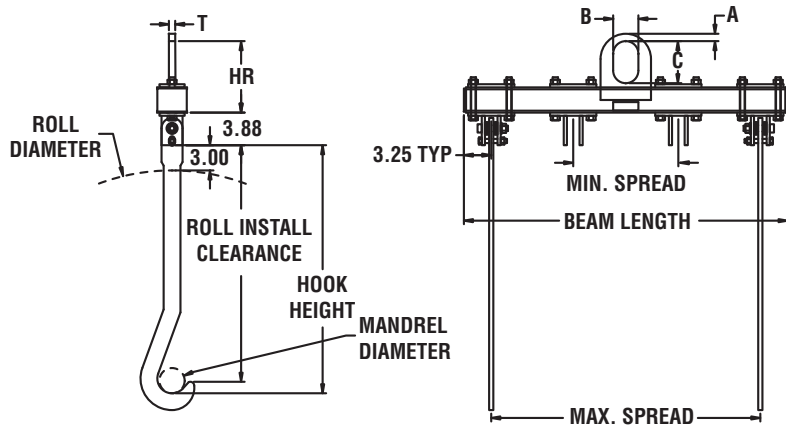

NOTE: Dimensions shown in inches.

SPECIFICATIONS

Capacity (tons)	Model Number	HR Headroom (in.)	Min. Spread (in.)	Max. Spread (ft.)						Hook Thickness (in.)	Bail (in.)			
				3	4	6	8	10	12		A	B	C	T
1/2	Model Number			23QS-1/2-3	23QS-1/2-4	23QS-1/2-6	23QS-1/2-8	23QS-1/2-10	23QS-1/2-12	1/2	7/8	3	5	3/4
	HR Headroom	8 1/2	8 1/2	8 1/2	8 1/2	9 1/2	9 1/2							
	Min. Spread	12	12	12	24	24	24							
1	Model Number			23QS-1-3	23QS-1-4	23QS-1-6	23QS-1-8	23QS-1-10	23QS-1-12	1/2	7/8	3	5	3/4
	HR Headroom	8 1/2	8 1/2	9 1/2	9 1/2	10 1/2	10 1/2							
	Min. Spread	12	12	12	24	24	24							
2	Model Number			23QS-2-3	23QS-2-4	23QS-2-6	23QS-2-8	23QS-2-10	23QS-2-12	1/2	7/8	3	5	3/4
	HR Headroom	9 1/2	9 1/2	10 1/2	11 1/2	12 1/2	12 1/2							
	Min. Spread	12	12	12	24	24	24							
3	Model Number			23QS-3-3	23QS-3-4	23QS-3-6	23QS-3-8	23QS-3-10	23QS-3-12	3/4	1 1/2	3	5	1
	HR Headroom	10 1/2	10 1/2	11 1/2	12 1/2	13 1/2	13 1/2							
	Min. Spread	12	12	24	24	24	24							
5	Model Number			23QS-5-3	23QS-5-4	23QS-5-6	23QS-5-8	23QS-5-10	23QS-5-12	1	2	4	7	1 1/4
	HR Headroom	13 1/2	14 1/2	15 1/2	17 1/2	17 1/2	19 1/2							
	Min. Spread	24	24	24	24	24	24							

Operation



Photo courtesy of J.B Kenehan Printing Services, Waukesha, WI