

Clamps, Grabs & Tongs

Model RLT – Rail Tongs



INSTOCK PROGRAM

PRODUCT FEATURES:

- Rail Tongs are designed to handle all standard size rails.
- Tongs are provided with non-slip machined diamond face gripping pads.
- Load must be balanced and controlled when lifting.
- Complies with ASME standards.

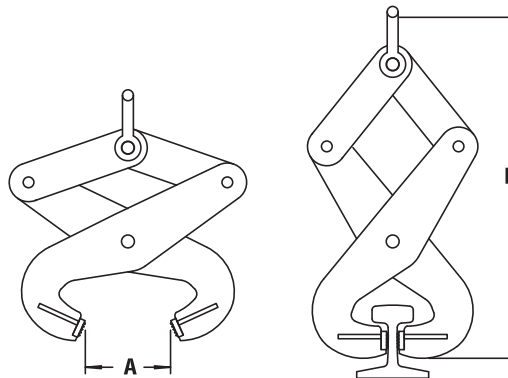

SPECIFICATIONS

Model Number	Rated Capacity (tons)	A (in.)	B (in.)	Handles	
				Std. ASCE Rail (# per yard)	Weight (lbs.)
109 - 1	1	3	18	30 & 40	15
109 - 2	2	5	20	50 - 100	18

Model MPP – Pallet Puller



INSTOCK PROGRAM

PRODUCT FEATURES:

- Used for moving hard to reach loaded pallets from flat surfaces, such as truck trailers or loading docks.
- Extends reaching capability of the fork lift truck.
- Single scissor action.
- Heavy duty steel design.
- Not for overhead lifting.
- Working load limit 1,250 pounds.
- 3/8" proof coil chain.

SPECIFICATIONS

Model Number	Jaw Opening (in.)		Chain Length (in.)	Weight (lbs.)
	Max.	Min.		
MPP-1	4.00	1.00	24	14

